

Raumvorstellung

Aufgabe 1081, Seite 242

1.

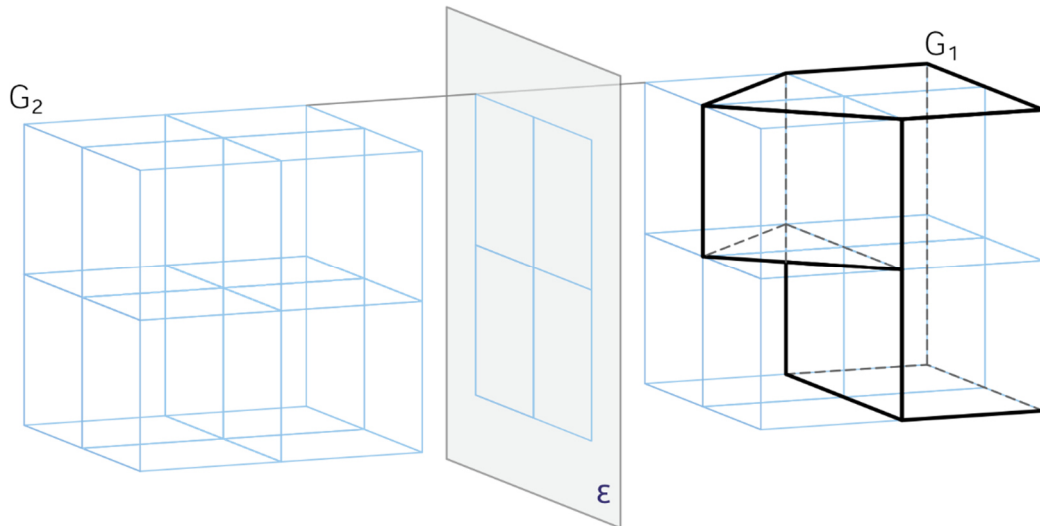

2.

